

Versatility, accessibility and intelligence are the key highlights of the recoSTAR universal recycling line. New advanced features complement a well-proven technology.

The **reCO** concept is an innovative approach that improves the energy efficiency of the recycling line. The overall energy consumption kW/kg is reduced by approx. 10 %. The benefit for the client is reduced costs, benefit for the environment is reduced carbon footprint.

The **reCO package** includes amongst others:

- ▶ New drive concept for the main extruder drive
- ▶ Main motors IE3 standard
- ▶ Free-angle cutting geometry for exact cutting and low energy consumption
- ▶ Barrel heating
- ▶ Energy recovery solutions are optionally available for various process steps.



Feeding via cyclone in-line with production line, nip roll feeder and conveyor belt. Material can be fed into the hopper in all shapes without pre-cutting.

Shredder design with curved pusher and increased buffer volume. Shredder bottom and dosing screw are opened hydraulically for easy access, allowing faster material and colour change-over.

Three-drive design ensures exact material dosing and output control.

User-friendly control panel design, RFID chip operator identification, LED elements for intuitive operation, automatic start-up and stand-by, one-button start/stop, etc.

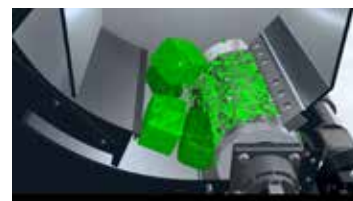

Exact cutting geometry with tight knife clearance and ideal stator/rotor knife arrangement ensures perfect material preparation. The slow-running rotor improves knife lifetime and overall reliability. Shredder rotor reverses automatically if required.

Low noise and vibration levels are setting new standards.

Extruder screw and barrel are wear resistant, optionally ultra wear resistant.



Easy maintenance is ensured by the large service opening; rotor and stator knife change is possible without moving the conveyor belt.

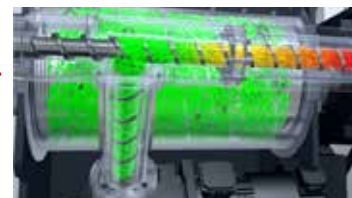

The innovative process adaption allows wide material variations. The load-controlled dosing screw ensures stable extruder feeding and perfect process stability.

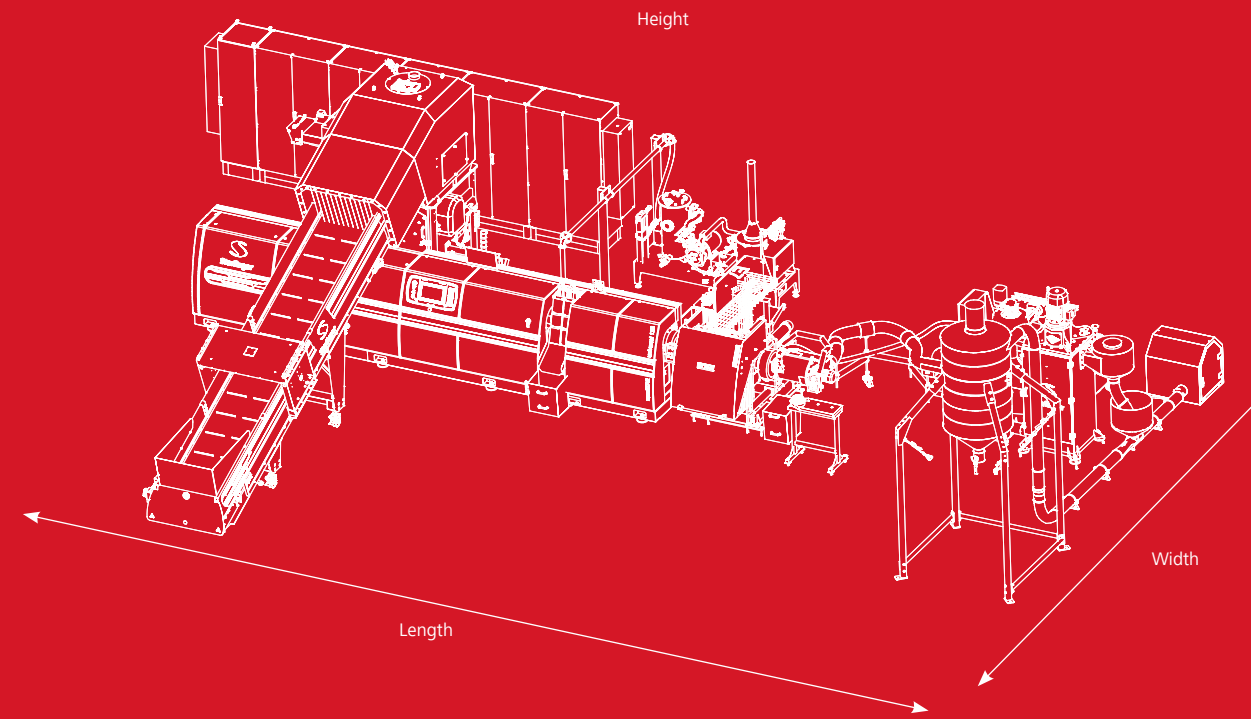

Dimensions		recoSTAR universal			
Type		105	125	145	165
Height [in mm]		4300	4300	5400	5400
Height [in inches]		170	170	210	210
Width [in mm]		7600	8500	11600	12500
Width [in inches]		300	300	460	490
Length (with degassing) [in mm]		11800	14000	17000	18800
Length (with degassing) [in inches]		460	550	670	740

Technical Data		recoSTAR universal			
Type		105	125	145	165
Output [kg/h]*		300 – 600	350 – 850	500 – 1050	650 – 1300
Output [lbs/h]*		660 – 1320	770 – 1870	1100 – 2320	1430 – 2870
Energy consumption [kWh/kg]		0,2 – 0,35	0,2 – 0,35	0,2 – 0,35	0,2 – 0,35
Energy consumption [kWh/lb.]		0.13 – 0.16	0.13 – 0.16	0.13 – 0.16	0.13 – 0.16
* without degassing					
ACTIVE shredder					
Shaft width [mm]		1200	1200	1500	2000
Shaft width [inch]		47.2	47.2	59.1	78.7
Drive power [kW]		90/110	90/110	132	132/160
Extruder					
Screw diameter (L/D) [mm]		105	125	145	165
Screw diameter (L/D) [inch]		4.1	4.9	5.7	6.5
L/D		24(40*)	24(40*)	24(40*)	24(40*)
AC drive [kW]		132/160	160/200	200/250	355
* with degassing					
Downstream equipment					
Degassing: vacuum, high vacuum		○	○	○	○
Water ring pelletiser		●	●	●	●
Strand/automatic strand pelletiser		alternative	alternative	alternative	alternative
Underwater pelletiser		alternative	alternative	alternative	alternative
● standard ○ option					

Starlinger recycling technology
 Furtherstrasse 47a
 2564 Weissenbach, Austria
 T: + 43 2674 800 3101
 F: + 43 2674 86328
 E: recycling@starlinger.com
 recycling.starlinger.com

Starlinger Head Office
 Sonnenuhrgasse 4
 1060 Vienna, Austria
 T: + 43 1 59955-0, F: -180

Starlinger & Co Gesellschaft m.b.H.
 A member of Starlinger Group

recoSTAR® is a registered trademark of Starlinger & Co Gesellschaft m.b.H.

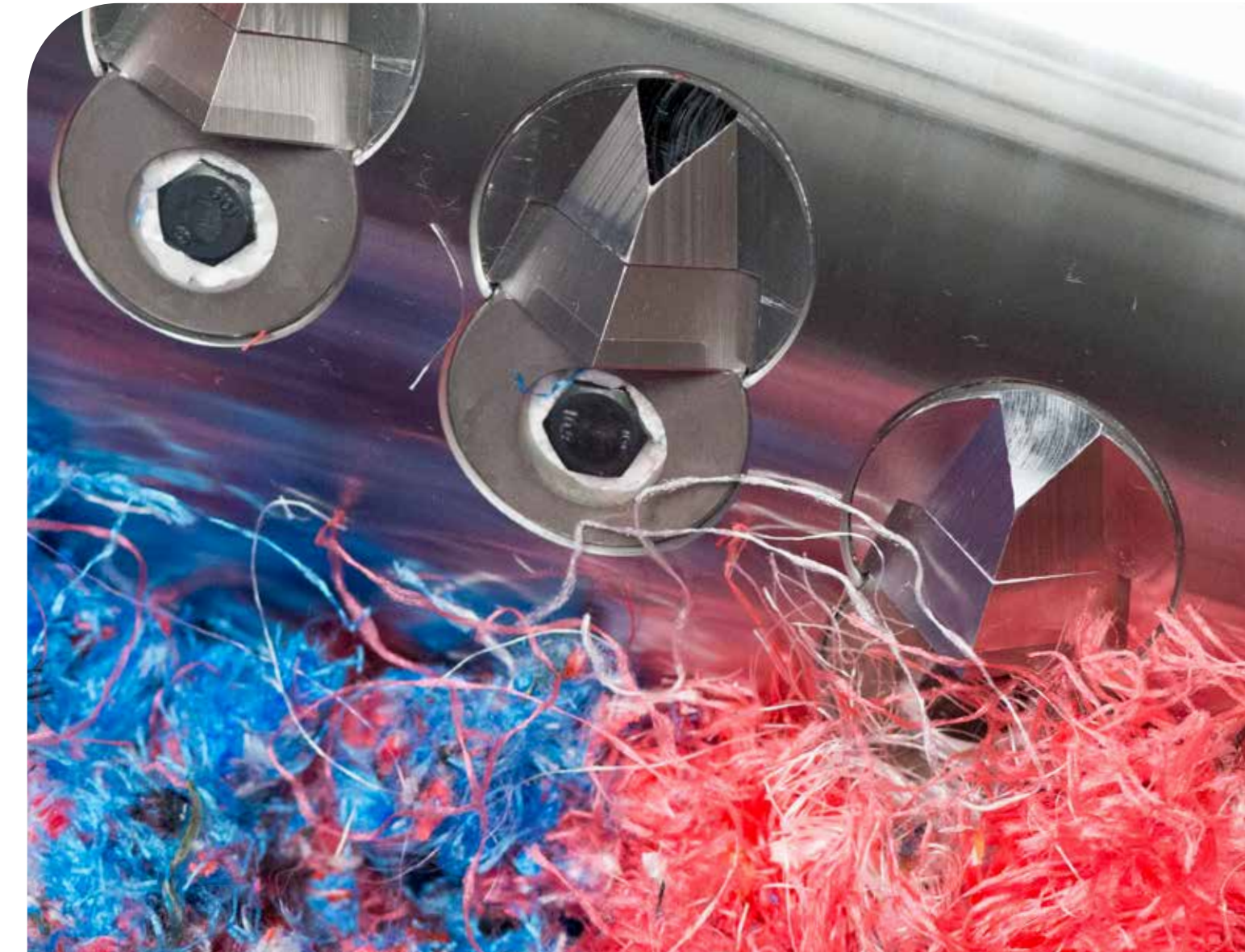

RECYCLING LINE recoSTAR universal

for production and post-industrial scrap, integrated ACTIVE shredder for hard-to-grind materials, innovative process adaption, quick access for fast material change-over, easy maintenance, high performance design





State-of-the-art recycling technology with extended functionality and innovative process adaption through the ACTIVE shredder. Designed for processing films, fibres and filaments, nonwovens, tapes, fabrics, as well as solid lumps, start-up scrap, injection moulding parts, and any type of regrind; from materials such as PE, PP, PS, PA, PES, PET, PPS, PLA, and others.



The ACTIVE shredder ensures perfect material preparation for high output through exact cutting geometry and double-coil rotor design. The load-controlled dosing screw allows stable extruder feeding even when the bulk density varies. Easy access and maintenance leads to high uptime and availability.



The optional degassing extruder purifies the melt from volatile contamination and monomers. High-vacuum degassing for hygroscopic polymers is optionally available. Wear-resistant extruder design.



A variety of melt filters for removing solid contaminants is available. The optional backflushing reduces costs for filter screens and operator intervention. In case of higher contamination a power backflushing or continuous filter is recommended.



The water ring pelletiser ensures exact cutting for high pellet quality and low operating costs. The remote control panel next to the pelletizer allows starting/stopping of the line also from this position. Alternatively, a strand, automatic strand, or underwater pelletiser can be used.



Compounding with powder, liquid or masterbatch allows to upcycle the plastic scrap. In-house masterbatch production with the Starlinger recoBATCH solution is possible. Consistent high pellet quality, up to 100% reuse in a variety of applications.



ACTIVE shredder

High performance ACTIVE shredder for rigid, flexibles and hard-to-grind materials without pre-cutting:

- A** accessibility & quick material change
- C** controlled cutting & dosing
- T** tight knife clearance & high performance
- I** intelligent & innovative
- V** versatile & wide material range
- E** easy start & stop operation

recoSTAR universal

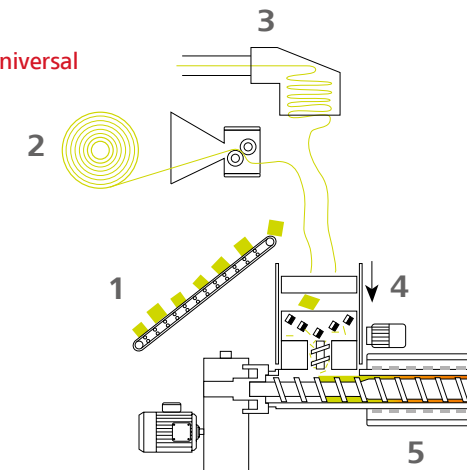

- 1. Conveyor belt
- 2. Nip roll feeder
- 3. Edge trim cyclone

- 4. ACTIVE shredder
- 5. Extruder

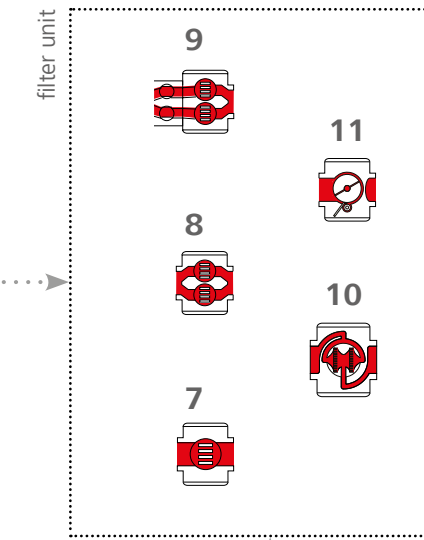

- 6. Degassing extruder
- 7. Melt filter, discontinuous
- 8. Melt filter without backflushing
- 9. Melt filter with backflushing

- 10. Melt filter with power backflushing
- 11. Continuous melt filter
- 12. Water ring pelletiser
- 13. Strand pelletiser

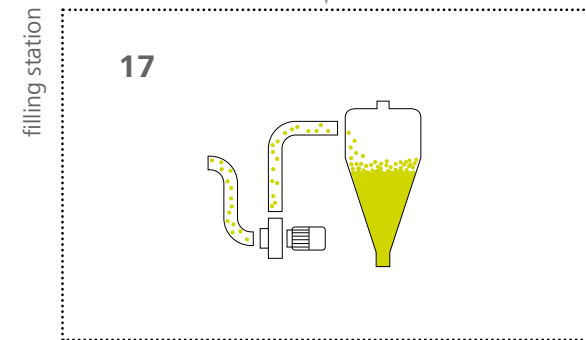
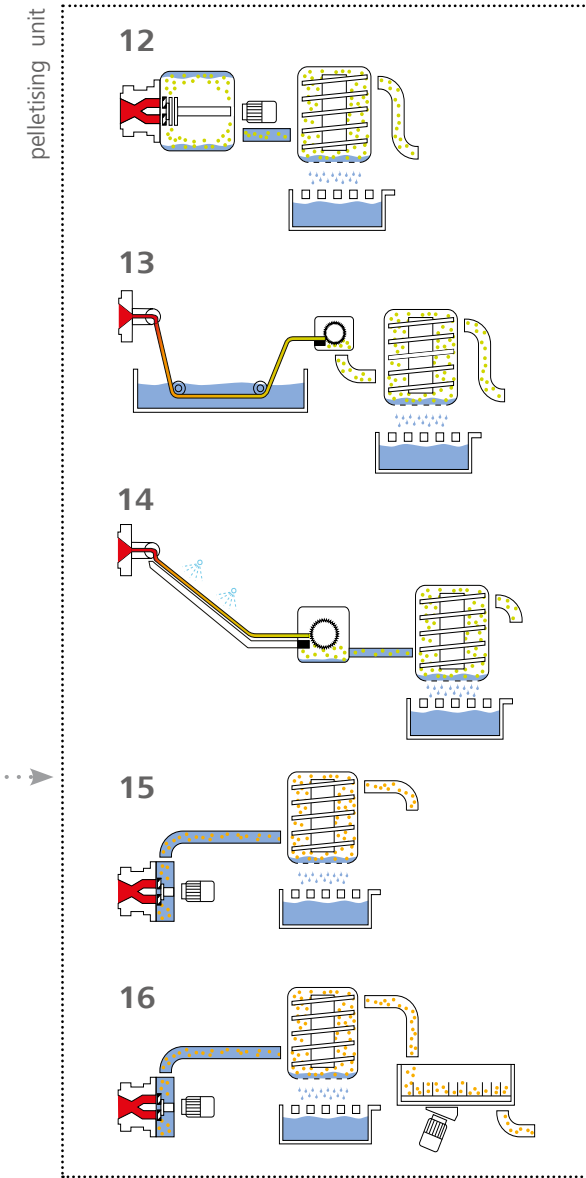

- 14. Automatic strand pelletiser
- 15. Underwater pelletiser (UWP)
- 16. UWP with inline crystallisation
- 17. Filling station

Machines pictured may include equipment sold as options.